



HEATING AND COOLING SOLUTIONS

SPLIT SYSTEMS





THE BEST AIR ANYWHERE

At Daikin, we're not just in the business of air conditioners. We're in the business of human comfort. Our passion for designing and engineering smart technologies ensures your comfort levels are maximised.

Daikin's recognised as an expert in air conditioning. As specialists, air conditioning is all we do. In fact, we're the only company in the world to make both air conditioners and refrigerants which enables us to deliver air conditioning solutions that are world leading in performance, quality and reliability.

CONTENTS

COMFORT REINVENTED	4
US7	6
ZENA	8
CORA	10
NEXURA	12
FLOOR STANDING	14
SUPER MULTI NX	16
VRV IV-S	18
D-MOBILE	20
AIR PURIFIER	21
THE SENSITIVE CHOICE	22
WHY CHOOSE A DAIKIN DEALER?	23
PRODUCT SPECIFICATIONS	24
FEATURES CHECKLIST	30

COMFORT REINVENTED

For over 90 years, Daikin has invested heavily in Research and Development to deliver more effective climate control for you and your family. Daikin technologies help make Daikin air conditioners energy efficient, powerful, reliable and easy to use.

Here are some examples of the innovative technology you can find in your Daikin split system.

GLOBAL WARMING POTENTIAL

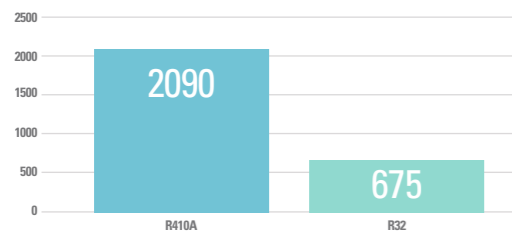

R32 REFRIGERANT

All Daikin wall mounted split systems use R32 refrigerant. With a lower global warming potential and a higher refrigeration potential than refrigerants such as R410A, R32 systems can deliver more efficient cooling and heating with less risk of harm to the environment.

LESS TEMPERATURE FLUCTUATION

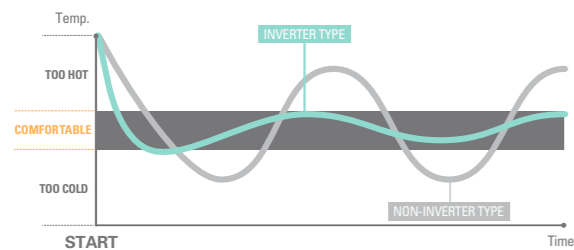

INVERTER TECHNOLOGY

An inverter system works like the accelerator of a car, gently increasing or decreasing power. They reach the desired temperature quicker and steadily maintain it without fluctuations. That means uninterrupted comfort and significant savings on running costs.



Neodymium Magnet
10x Stronger

RELUCTANCE DC MOTOR

Our outdoor units incorporate Daikin's Reluctance DC motors. These motors which drive our compressors, utilise the magnetic torque of neodymium magnets in conjunction with reluctance torque, which can boost efficiency by up to 40% more than conventional motors.

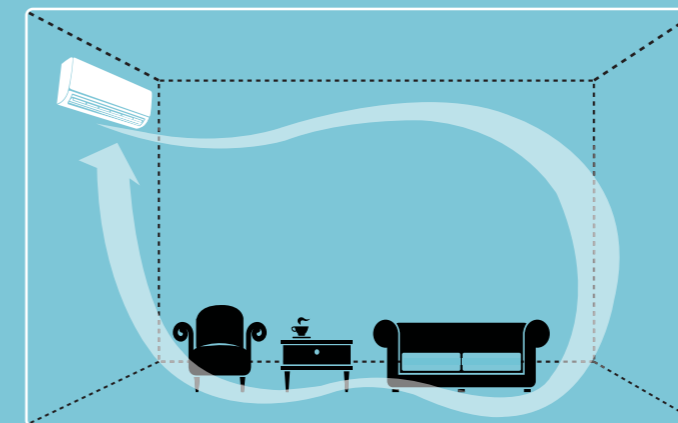

COANDA AIRFLOW TECHNOLOGY

Our wall mounted indoor units* feature an advanced louvre design for streaming air upwards along the ceiling and creating a circulatory air motion in the occupied space. This ensures rapid cooling of the area, even temperature distribution and improved comfort levels.

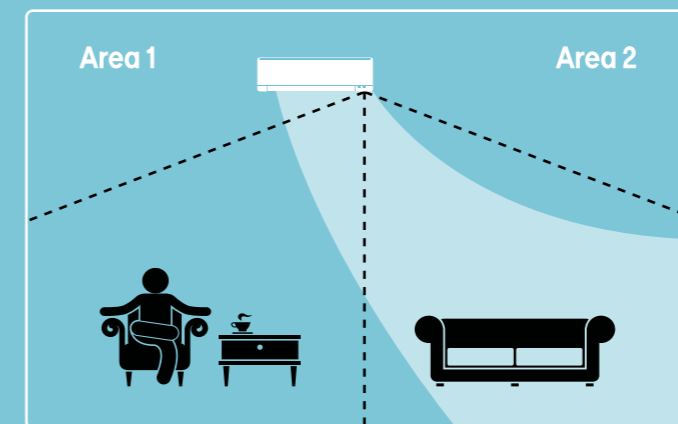

INTELLIGENT EYE SENSOR

Each indoor wall mounted model is fitted with Daikin's trademark Intelligent Eye human sensor. This sensor cleverly switches the unit into energy saving mode when the room is unoccupied. On models fitted with the more advanced 2-Area variant, the intelligent eye can also be used to provide draught free comfort.

Draught free comfort operations: If occupant detected in area 1, airflow is directed away

*Only applicable to Cora 20-71 Class Models and all US7 Models

Top of its class and packed with advanced technologies, US7 delivers ultimate comfort with its humidifying, dehumidifying, ventilating and air purification features.



2.5kW
-TO-
5.0kW
CAPACITY RANGE

3
MODELS

REVERSE
CYCLE

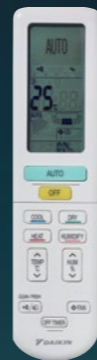

US7

AS SMART, AS IT IS STYLISH



INDUSTRY LEADING

US7 is the first split system in Australia to be awarded a 7-star 'Super Efficiency' rating*. It is also packed with advanced technologies and a range of innovative features that distinguishes US7 from every other.



ADVANCED HUMIDIFICATION

Excessively dry air can cause dry skin and a sore throat. Our advanced humidification unit in the outdoor unit draws moisture from outdoor air and distributes this indoors to make you feel warmer and more comfortable.



R32 REFRIGERANT

R32 is the next generation in refrigerants with a substantially lower 'Global Warming Potential Factor' than R410A, providing less risk of harm to the environment.



COANDA AIRFLOW

Discharge louvres are specially designed to stream air upwards along the ceiling for longer throws and delivering rapid cooling and even temperature distribution in the occupied space.



POWERFUL DEHUMIDIFICATION

Through intelligent control of the indoor heat exchanger and mixing warmer room air with dehumidified air, US7 cleverly reduces humidity without making your room too cold and uncomfortable.



UNIQUE TWO-STAGE FILTRATION

While the outdoor unit removes carbon monoxide, exhaust gasses and bad odours via a thermal catalyst, the indoor unit's flash streamer technology removes mould, formaldehyde and other allergens from the air keeping your room's air fresh and clean.

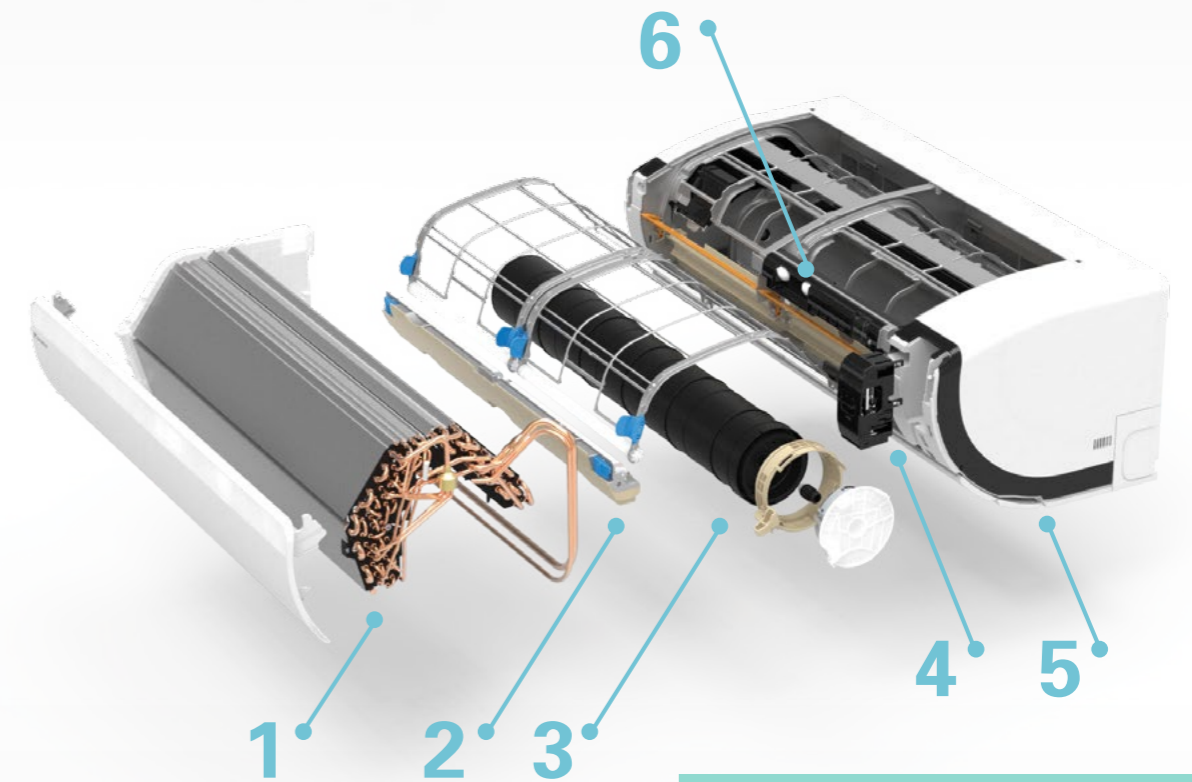

D-Mobile Interface (Option)

Daikin's D-Mobile Smartphone Interface allows you to control your Daikin Split System from anywhere, anytime.

TECHNOLOGY

1. HIGH DENSITY HEAT EXCHANGER

US7's five row heat exchanger utilising Ø5mm copper piping delivers superior cooling and heating performance.

2. AUTOMATIC SELF CLEANING FILTER

An internal brush automatically collects and deposits dust from the air filter to help maintain stable airflow and minimise power consumption.

3. HYPER SAW EDGE FAN

Unique 'Saw Edge' design of the indoor fan rotor delivers superior airflow and quiet operations as low as 19dBA (25-35 Class Model).

4. FLASH STREAMER TECHNOLOGY

Decomposes bacteria and mould absorbed on the filter by ionisation with an advanced plasma electric discharge.

5. NATURAL BREEZE AIRFLOW

By randomly varying airflow and direction, US7 simulates the sensation of a gentle breeze for improved comfort.

6. 2-AREA INTELLIGENT EYE

Ensures draught free comfort. If no movement detected for a period of 20 minutes, the air conditioner adjusts the set temperature by ±2°C to save energy.

ENERGY RATING

CLASS		25	35	50
STAR RATING	COOL	★★★★★★★	★★★★★☆☆	★★★★☆☆
	HEAT	★★★★★★★	★★★★★☆☆	★★★★☆☆

The more stars, the more energy efficient. The Star Rating Index is determined under conditions of AS/NZS 3823.1.1

Engineered in Europe with the latest technology, its stylish and elegant design seamlessly integrates into the modern home.



REVERSE
CYCLE
SILVER OR
WHITE FINISH

2.5kW
-TO-
5.0kW
CAPACITY RANGE

6
MODELS

ZENA

DESIGNED TO IMPRESS



R32 REFRIGERANT

R32 is the next generation in refrigerants with a substantially lower 'Global Warming Potential Factor' than R410A, providing less risk of harm to the environment.



INVERTER POWERFUL OPERATION

Push the POWERFUL button on the remote control and you'll be relieved with a cooling or heating boost for a 20 minute period, even if the unit's already operating at high capacity.



INTELLIGENT COMFORT

Daikin's 2-area Intelligent Eye human sensor helps direct airflow away from you for draught free comfort and automatically enables energy saving operations when the room is unoccupied.



PROGRAM DRY FUNCTION

Besides reducing humidity, this function automatically controls temperature and airflow rate and will cleverly switch into cooling mode if the room temperature rises too much.



AIR PURIFICATION

Each model is fitted with a titanium apatite deodorising air purification filter that traps microscopic particles, decomposes odours and even deactivates bacteria.



COMFORT MODE

Airflow direction is optimised such that airflow is streamed upwards during cooling to prevent cold airflow being blown onto the body and downward during heating to drive warm air towards the floor of the room.

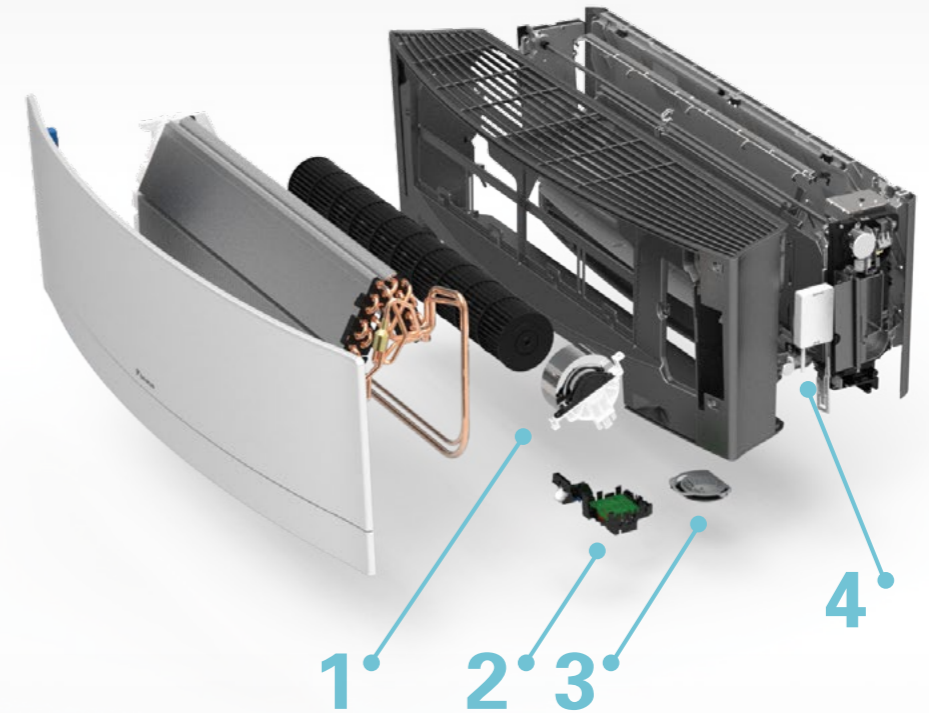

D-Mobile Interface (Option)

Daikin's D-Mobile Smartphone Interface allows you to control your Daikin Split System from anywhere, anytime.

TECHNOLOGY

1. DC FAN MOTOR

Daikin's DC Fan Motor is efficient and compact, featuring five step fan speeds including quiet and auto mode.

2. 2-AREA INTELLIGENT EYE

Ensures draught free comfort and if no movement detected for a period of 20 minutes, the air conditioner adjusts the set temperature by $\pm 2^{\circ}\text{C}$ to save energy.

3. MULTI COLOUR MONITOR LAMP

LED lamp lights up a different colour based on operation mode for easy identification and convenient monitoring at a glance.

4. INTEGRATED CONNECTIVITY

The optional D-Mobile Wireless LAN module can be conveniently placed into an internal housing compartment in the Zena indoor unit.

ENERGY RATING

CLASS		25	35	50
STAR RATING	COOL	★★★★★	★★★	★★
	HEAT	★★★★★	★★★★★	★★★★

The more stars, the more energy efficient. The Star Rating Index is determined under conditions of AS/NZS 3823.1.1

Delivered in understated confidence, featuring whisper quiet operation, industry leading energy efficiency and premium comfort levels without compromising on style.



2.0kW
-TO-
9.4kW
CAPACITY RANGE

16
MODELS

REVERSE
CYCLE OR
COOLING
ONLY



CORA

STYLED TO PERFORM

R32 REFRIGERANT
R32 is the next generation in refrigerants with a substantially lower 'Global Warming Potential Factor' than R410A, providing less risk of harm to the environment.

COANDA AIRFLOW
Discharge louvres are specially designed to stream air upwards along the ceiling for longer throws and delivering rapid cooling and even temperature distribution in the occupied space.

INVERTER POWERFUL OPERATION
Push the POWERFUL button on the remote control and you'll be relieved with a cooling or heating boost for a 20 minute period, even if the unit's already operating at high capacity.

INTELLIGENT COMFORT
The New 2-area Intelligent Eye is so clever it can now either direct airflow towards you or away from you for draught free comfort. If the room is unoccupied the unit will automatically enable energy saving operations.

PRECISION CONTROL
For even greater precision and control, you can now set your room temperature in increments of 0.5°C to ensure optimal comfort conditions all year round.

AIR PURIFICATION
Each model is fitted with a titanium apatite deodorising air purification filter that traps microscopic particles, decomposes odours and even deactivates bacteria.

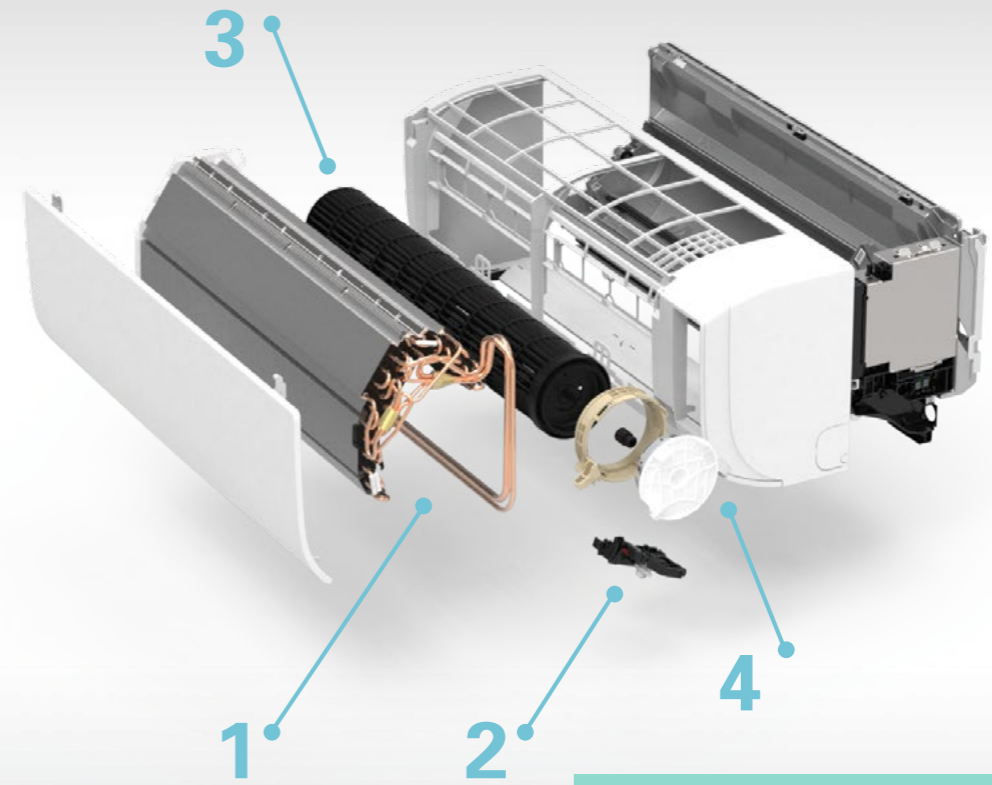

D-Mobile Interface (Option)
Daikin's D-Mobile Smartphone Interface allows you to control your Daikin Split System from anywhere, anytime.

TECHNOLOGY

1. REDESIGNED HEAT EXCHANGER
Slit type fin design with Ø5mm piping increases heat exchange area for improved capacity output and energy performance.

2. NEW 2-AREA INTELLIGENT EYE
Gives you the option to direct airflow either towards or away from you for draught free comfort. If no occupation is detected, the air conditioner operates in energy saving mode.

3. CROSS FLOW FAN
Large diameter rotor with aerofoil blade design delivers larger volumes of air more quietly than ever before.

4. NEW ODM MOTOR
Compact 10 pole DC outer diameter rotor motor delivers higher torque more efficiently.

ENERGY RATING

CLASS		20	25	35	46	50
STAR RATING	COOL	★★★★★	★★★★★	★★★★☆	★★★☆☆	★★★★★
	HEAT	★★★★★	★★★★★	★★★★★	★★★★☆	★★★★★
		60	71	85	95	
		★★★★	★★★☆☆	★★★☆☆	★★★☆☆	★★★☆☆
		★★★★☆	★★★★	★★★★	★★★☆☆	★★★★

The more stars, the more energy efficient. The Star Rating Index is determined under conditions of AS/NZS 3823.1.1. Cooling Only models are available from 20 to 71 Class, heating Star Rating does not apply.

European designed floor standing heat pump that is quiet, discrete and features state-of-the-art heating technology from its unique front radiant heat panel.

2.5kW
-TO-
4.8kW
CAPACITY RANGE

3
MODELS



NEXURA

BEST OF BOTH WORLDS



RADIANT MODE

At the touch of a button, Nexura's aluminium front panel warms up just like a traditional radiator. The result is a comfortable feeling of warm air that envelopes you with a quieter heating experience.



PROGRAM DRY FUNCTION

Besides reducing humidity, this function automatically controls temperature and airflow rate and will cleverly switch into cooling mode if the room temperature rises too much.



ECONO MODE

This mode limits the maximum power consumed by the system preventing the tripping of your circuit breaker should you have other household appliances operating simultaneously with your air conditioner.



SUPERIOR HEATING

As stylish as it is, Nexura is also powerful. It is able to reach your desired temperature rapidly by operating the unit in 'powerful' heating mode which circulates warm air throughout your room effectively.



HOT START

Prior to heating, the indoor unit warms to a pre-set temperature before the fan switches on, ensuring only warm air is discharged and eliminating cold draughts.



AIR PURIFICATION

Each model is fitted with a titanium apatite deodorising air purification filter that traps microscopic particles, decomposes odours and even deactivates bacteria.

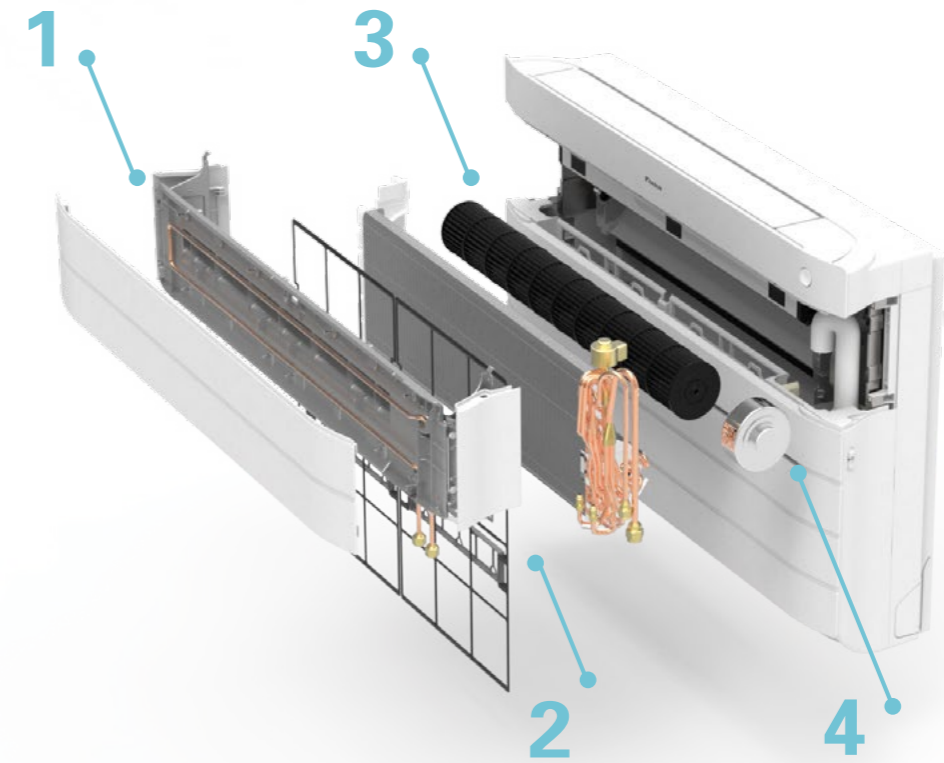

TECHNOLOGY

1. RADIANT PANEL

Aluminium panel connected to a sub heat exchanger enables radiant heating with panel surface temperatures of up to 55°C.

2. ADVANCED FILTRATION

Features the combination of a particulate pre-filter for collecting dust particles and a titanium apatite deodorising air purification filter.

3. CROSS FLOW FAN

Large diameter rotor with aerofoil blade design delivers larger volumes of air more quietly than ever before.

4. DC FAN MOTOR

Daikin's DC Fan motor is efficient and compact, featuring five step fan speeds including quiet and auto mode.

ENERGY RATING

CLASS		25	35	50
STAR RATING	COOL	★★★★★	★★★☆☆	★★☆☆*
	HEAT	★★★★★	★★★★☆	★★★★☆

The more stars, the more energy efficient. The Star Rating Index is determined under conditions of AS/NZS 3823.1.1

Compact floor standing unit with a wide selection of capacities, ideal for placement under a window sill or semi-recessed into a unused fireplace.

2.5kW
-TO-
7.1kW
CAPACITY RANGE

6
MODELS



FLOOR STANDING

COMPACT & CONVENIENT



DUAL DISCHARGE VENTS

You can select to use either top, or top and bottom discharge vents to distribute air evenly through the room for better heating comfort.



ECONO MODE

This mode limits the maximum power consumed by the system preventing the tripping of your circuit breaker should you have other household appliances operating simultaneously with your air conditioner.



WIDE OPERATING RANGE

Daikin's floor standing units are robust in design and feature an intelligent defrost system. So even when the mercury drops as low as -10°C, your home still stays comfortable in winter.



STANDBY POWER FUNCTION

When the system is not in use, power supply to the outdoor unit is turned off and the indoor unit switches to standby mode.



HOT START

Prior to heating, the indoor unit warms to a pre-set temperature before the fan switches on, ensuring only warm air is discharged and eliminating cold draughts.



AIR PURIFICATION

Each model is fitted with a titanium apatite deodorising air purification filter that traps microscopic particles, decomposes odours and even deactivates bacteria.

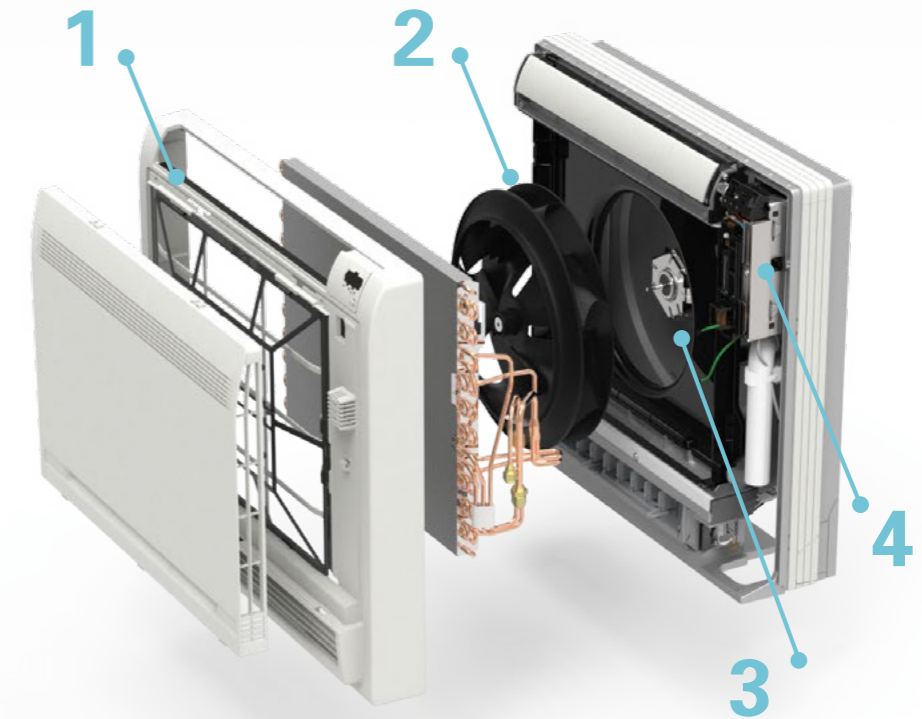

TECHNOLOGY

1. ADVANCED FILTRATION

Features the combination of a particulate prefilter for collecting dust particles and a titanium apatite deodorising air purification filter.

2. TURBO FAN

The large swept blades enable air to be discharged quietly and efficiently via both the top and bottom discharge vents for even airflow into the room.

3. DC FAN MOTOR

Daikin's DC Fan motor is efficient and compact, featuring five step fan speeds including quiet and auto mode.

4. PROGRAM DRY FUNCTION

When operating in this mode, the microprocessor intelligently adjusts temperature and airflow rate to reduce humidity with minimal compromise to comfort.

ENERGY RATING

CLASS	25	35	45	50	60	71
STAR RATING						
COOL	★★★★☆	★★★★	★★★	★★★★	★★★★☆	★★★
HEAT	★★★★★	★★★★	★★★★☆	★★★★★	★★★	★★★

The more stars, the more energy efficient. The Star Rating Index is determined under conditions of AS/NZS 3823.1.1

Note: Please see features checklist on page 30 for full list of features

If you're after multi room air conditioning, Daikin's Super Multi NX is the clever choice. It takes only one Super Multi NX outdoor unit to maintain comfort in up to five rooms.



5.2kW
-TO-
10.0kW
CAPACITY RANGE

8
MODELS

REVERSE
CYCLE OR
COOLING
ONLY

SUPER MULTI NX

MAKE EVERY ROOM A COMFORT ZONE



DESIGN FLEXIBILITY

Daikin's multi room air conditioners use a single outdoor unit connected to multiple indoor units, thus reducing the outdoor space required and simplifying the installation.



CONVENIENT CONTROL

For convenient controls, both our wired and wireless controllers enable individual control of settings such as temperature, airflow volume and scheduled operations.



TRULY VERSATILE

As many as 5 indoor units can be connected to a single outdoor unit combined with a broad selection of indoor units ranging from wall mounted, floor standing, bulkhead, cassettes and ceiling suspended units.



PRIORITY ROOM SETTING

The feature allows you to shift capacity from the other rooms to your priority room when required for rapid cooling or heating of that space.



INDIVIDUAL COMFORT

Each indoor unit can be individually controlled, scheduled and set to the desired room temperature ensuring optimal comfort for all occupants in the household at anytime.*



INTELLIGENT COMFORT

Wall mounted indoor units feature Daikin's Intelligent Eye human sensor that ensures draught free comfort and automatically enables energy saving operations when the room is unoccupied.

INDOOR UNIT TYPES

ZENA WALL MOUNTED



FLOOR / CEILING SUSPENDED



WALL MOUNTED

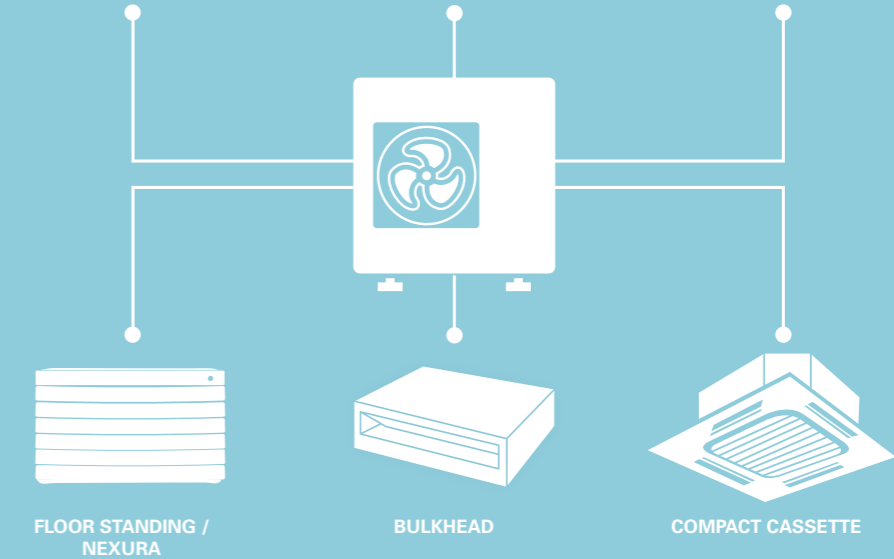

Note: Please refer to the below 'Outdoor Units' table for the maximum number of connectable indoor units for each outdoor unit model

INDOOR AND OUTDOOR UNIT RANGE

INDOOR UNITS							OUTDOOR UNITS					
TYPE	CYCLE	MODEL	CAPACITY CLASS					MAXIMUM CONNECTABLE INDOOR UNITS	CYCLE	MODEL	CAPACITY (KW)	
			20	25	35	50	60					71
Wall Mounted	Cooling Only	FTKS-K(A)VMA	✓	✓	✓	✓	✓	Up to 3 Indoor Units	Cooling Only	3MKS58LVMA9	5.8	
	Reverse Cycle	FTXS-K(A)VMA	✓	✓	✓	✓	✓			3MKS68LVMA9	6.8	
Wall Mounted - Zena	Reverse Cycle	CTXG-PVMAW (White)	x	✓	✓	✓	x		Reverse Cycle	3MXS52LVMA9	5.2	
	Reverse Cycle	CTXG-PVMAS (Silver)	x	✓	✓	✓	x			3MXS68LVMA9	6.8	
Floor Standing	Reverse Cycle	FVXS-KV1A	x	✓	✓	✓	x		Up to 4 Indoor Units	Cooling Only	4MKS80LVMA9	8.0
Floor Standing - Nexura	Reverse Cycle	FVXS-KV1B	x	✓	✓	✓	x			Reverse Cycle	4MXS80LVMA9	8.0
Compact Cassette	Cooling Only	FFQ-BV1B9	x	✓	✓	✓	x	Up to 5 Indoor Units	Cooling Only	5MKS100LVMA9	10.0	
	Reverse Cycle	FFQ-BV1B9	x	✓	✓	✓	x			Reverse Cycle	5MXS100LVMA9	10.0
Bulkhead - 900/1,100mm Width	Cooling Only	CDKS-CVMA	x	✓	✓	✓	x	Bulkhead - 900/1,100mm Width	Reverse Cycle	FDXS-CVMA	x	
	Reverse Cycle	FDXS-CVMA	x	✓	✓	✓	x					
Bulkhead Compact - 700mm Width	Cooling Only	CDKS-EAVMA	x	✓	✓	x	x	Bulkhead Compact - 700mm Width	Reverse Cycle	CDXS-EAVMA	x	
	Reverse Cycle	CDXS-EAVMA	x	✓	✓	x	x					
Floor/Ceiling Suspended Dual	Reverse Cycle	FLXS-B(G)VMA	x	✓	✓	✓	x					

*User can select the unit to operate in either cooling or heating mode, not both cooling and heating simultaneously. Please see Super Multi NX brochure for full details and specifications

The ultimate multi room air conditioning system with a wide selection of indoor and outdoor units to suit a variety of room sizes and designs for medium to large size homes.



REVERSE CYCLE

9.0kW
-TO-
24.0kW
CAPACITY RANGE

6
MODELS

VRV IV-S

BRINGING INNOVATION TO YOUR HOME



ADVANCE TECHNOLOGY

VRV IV-S incorporates the latest technology from our VRV commercial air conditioners including remarkable energy efficiency, quiet operations and long piping runs of up to 100m* for flexible condenser placement.



COMPACT FOOTPRINT

VRV IV-S is available in a range of capacities from 9.0kW up to 24.0kW whilst maintaining a compact installation footprint. This allows you to place the outdoor unit out of sight without compromise to your home's external decor.



ULTIMATE VERSATILITY

As many as 14 indoor units can be connected to a single outdoor unit combined with a wide selection of indoor units ranging from wall mounted, floor standing, bulkhead, ducted, cassettes and ceiling suspended units.



INDIVIDUAL COMFORT

Each indoor unit can be individually controlled, scheduled and set to the desired room temperature ensuring optimal comfort for all occupants in the household at anytime.**



WHISPER QUIET

VRV IV-S is not just compact in size but also quiet in operations, featuring a night time quiet mode that reduces the outdoor unit noise level down to 43dBA (11.2kW Model) for minimal impact to the neighbours.



INTELLIGENT COMFORT

Wall mounted indoor units feature Daikin's Intelligent Eye human sensor that ensures draught free comfort and automatically enables energy saving operations when the room is unoccupied.

INDOOR UNIT TYPES

ZENA WALL MOUNTED



FLOOR / CEILING SUSPENDED



WALL MOUNTED

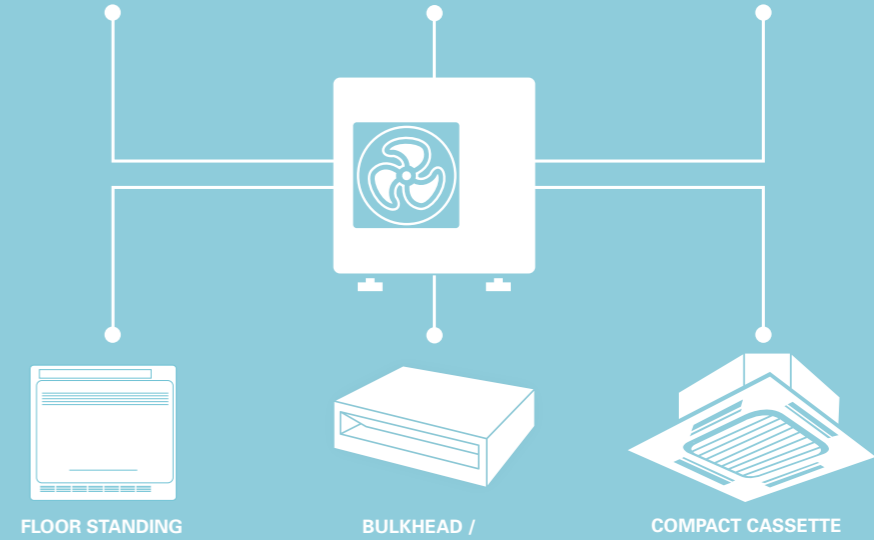

Note: Please refer to the below 'Outdoor Units' table for the maximum number of connectable indoor units for each outdoor unit model

INDOOR AND OUTDOOR UNIT RANGE

TYPE	MODEL	INDOOR UNITS																	
		CAPACITY CLASS																	
		20	25	32	35	40	50	60	63	71	80	100	125	140	145	160	180	200	250
Wall Mounted	FTXS-K(A)VMA	✓	✓	✗	✓	✗	✓	✓	✗	✓	✗	✗	✗	✗	✗	✗	✗	✗	✗
Wall Mounted - Zena	CTXG-PVMAW (White)	✗	✓	✗	✓	✗	✓	✗	✗	✗	✗	✗	✗	✗	✗	✗	✗	✗	✗
	CTXG-PVMAS (Silver)	✗	✓	✗	✓	✗	✓	✗	✗	✗	✗	✗	✗	✗	✗	✗	✗	✗	✗
Floor Standing	FVXS-KV1A	✗	✓	✗	✓	✗	✓	✗	✗	✗	✗	✗	✗	✗	✗	✗	✗	✗	✗
Compact Cassette	FFQ-BV1B9	✗	✓	✗	✓	✗	✓	✓	✗	✗	✗	✗	✗	✗	✗	✗	✗	✗	✗
Bulkhead - 900/1,100mm Width	FDXS-CVMA	✗	✓	✗	✓	✗	✓	✓	✗	✗	✗	✗	✗	✗	✗	✗	✗	✗	✗
Bulkhead Compact - 700mm Width	CDXS-EAVMA	✗	✓	✗	✓	✗	✗	✗	✗	✗	✗	✗	✗	✗	✗	✗	✗	✗	✗
Floor/Ceiling Suspended Dual	FLXS-B(G)VMA	✗	✓	✗	✓	✗	✓	✓	✗	✗	✗	✗	✗	✗	✗	✗	✗	✗	✗
Ceiling Mounted Built-in	FXSQ-PVE	✓	✓	✓	✗	✓	✓	✗	✓	✗	✓	✓	✓	✗	✗	✗	✗	✗	✗
Ceiling Concealed Ducted	FXDYQ-MAV1	✗	✗	✗	✗	✗	✗	✗	✗	✗	✓	✓	✓	✗	✓	✗	✗	✗	✗
	FXMQ-PV1A	✗	✗	✗	✗	✗	✗	✗	✗	✗	✗	✗	✗	✗	✗	✓	✓	✓	✓

OUTDOOR UNITS		
MAXIMUM CONNECTABLE INDOOR UNITS	MODEL	CAPACITY (KW)
Up to 5 Indoor Units	RXYMQ3AV4A	9.0
Up to 6 Indoor Units	RXYMQ4AV4A	11.2
Up to 8 Indoor Units	RXYMQ5AV4A	14.0
Up to 9 Indoor Units	RXYMQ6AV4A	16.0
Up to 13 Indoor Units	RXYMQ8AY1	22.4
Up to 14 Indoor Units	RXYMQ9AY1	24.0

*Applies to 16.0kW to 24.0kW models only

**User can select the unit to operate in either cooling or heating mode, not both cooling and heating simultaneously
Please see VRV IV-S brochure for full details and specifications



D-MOBILE

WI-FI CONTROL FOR YOUR DAIKIN WALL MOUNTED SPLIT

D-Mobile puts your air conditioner's frequently used functions at your finger tip with an easy to use app. In conjunction with Daikin's BRP072A42 wireless LAN adaptor, the easy to use D-Mobile app lets you use your smartphone or tablet to operate your Daikin wall mounted air conditioning unit via Wi-Fi or the internet.

THREE WAYS TO CONNECT

1. DIRECT CONNECTION

For locations without a Wi-Fi network, the app can wirelessly connect directly to the a wireless LAN adaptor equipped air conditioner, when in range.

2. WI-FI CONNECTION

A LAN equipped air conditioner can easily be joined to a local Wi-Fi network. Once connected, the system can be controlled from any networked Android or iOS device.

3. INTERNET CONNECTION

Monitor and control your system from virtually anywhere, adjusting temperature and setting for a comfortable environment ready for when you arrive home. With no subscription costs from Daikin, all you need is a permanent internet connection for your Wi-Fi network, and an internet connection for your phone or tablet.

FEATURES

FUNCTION	ZENA	CORA	US7
Start/stop operation	✓	✓	✓
Set operation mode: Auto/Cool/Heat/Fan/Dry	✓	✓	✓
Set temperature operation	✓	✓	✓
Set fan speed	✓	✗	✗
Set airflow direction	✓	✗	✗
Show room temperature	✓	✓	✓
Show outdoor temperature	✓	✓	✓
Error notification	✓	✓	✓
Set weekly schedule: - Start/stop operation - Select operation mode - Set temperature Maximum 4 actions per day	✓	✓	✓
Child lock	✓	✗	✗
Password setting	✓	✓	✓

The D-Mobile app is available for download, free from the Apple App Store or Google Play.

To download the D-Mobile app, search 'Daikin Mobile Controller' in the Apple App Store or Google Play. It will appear as D-Mobile app once downloaded.

DON'T COMPROMISE ON HEALTH AND COMFORT. BREATHE EASY WITH DAIKIN'S AIR PURIFIER.

Turn your home into the great indoors with Daikin's Air Purifier, featuring breathtaking technology, compact portable design and ultra quiet operation.

420 M³/H
AIR FLOW RATE

46 M²
ROOMS UP TO

AIR PURIFIER

CLEANER, FRESHER, HEALTHIER AIR

Daikin's Air Purifier includes a 6-layer powerful decomposition and removal system to help eliminate bacteria, mould spores, airborne particles, allergens, dust, pollen and unpleasant odours.

It is also ultra quiet with operating sound levels of as low as 16dBA which means you can not only sleep soundly at night, but also with peace of mind.



6 LAYER FILTRATION SYSTEM

1. Streamer Discharge Unit
2. Prefilter
3. Plasma Ioniser
4. Electrostatic Filter
5. Titanium Apatite Deodorising Filter
6. Deodorising Catalyst Filter

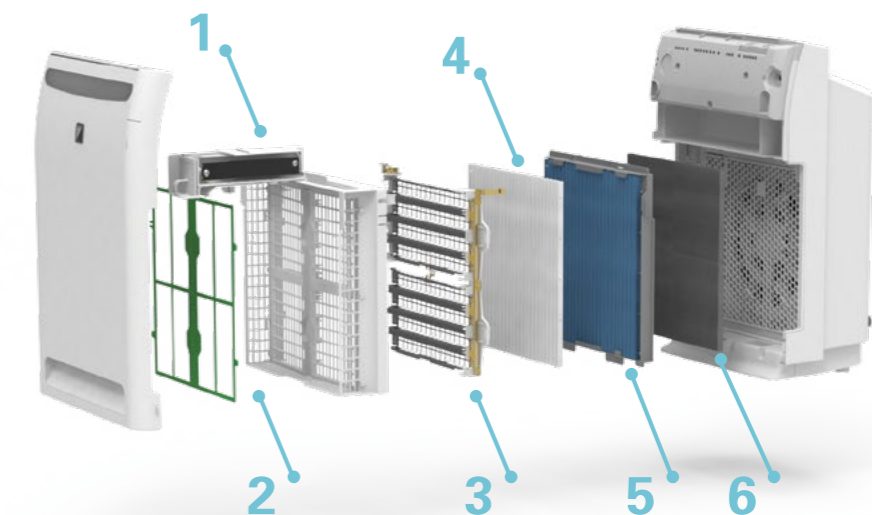

Please see Daikin Air Purifier brochure for full details and specifications



THE SENSITIVE CHOICE FOR YOUR HOME

We're proud of our innovations. So we're pleased to announce that Daikin is the only Split System to receive approval from the National Asthma Council Australia. They introduced the Sensitive Choice® program to help identify products better suited for people who suffer from asthma and allergies. Daikin Split Systems and Air Purifiers are recognised by the Sensitive Choice® program, and carry the Blue Butterfly symbol.

DAIKIN CARES FOR YOUR AIR

All Daikin Split Systems and Air Purifiers are designed with an air-purifying filter. Many are fitted with a more advanced Titanium Apatite Deodorising Air Purification filter. These filters not only trap most microscopic airborne particles, but also assist to decompose odours, absorb and deactivate bacteria. Music to the ears of every sensitive nose.



WHY CHOOSE A DAIKIN SPECIALIST DEALER?

Like us, our Dealers are specialists. They know the ups and downs, ins and outs of air conditioning. So their expertise ensures you get the right advice for your needs.

Daikin Specialist Dealers provide custom designed solutions for your home through an in-home quotation. Dealers will not only supply and install the best possible air conditioning solution but will also provide ongoing maintenance to ensure peak efficient performance over the life of the system.

To take the stress out of air conditioning your home, speak to a Daikin Specialist Dealer. With over 450 Specialist Dealers across Australia, our specialists are ready to help you fit the right air conditioning solution for your home.

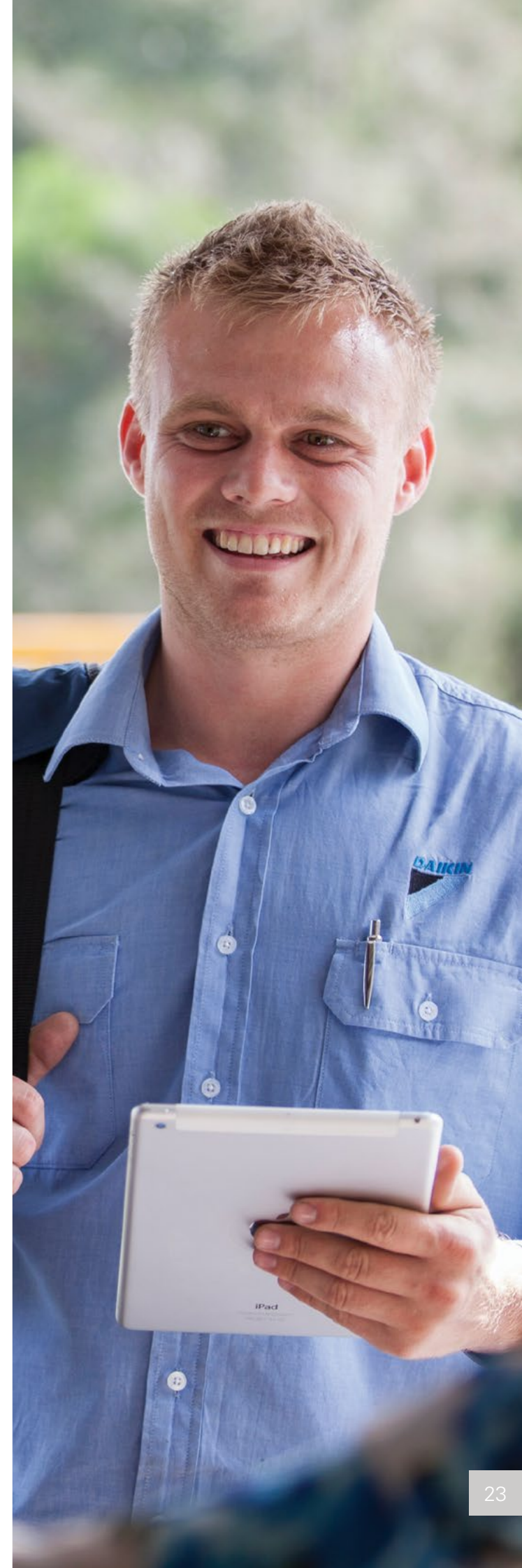

PRODUCT SPECIFICATION

US7 - Reverse Cycle



INDOOR UNIT		FTXZ25NV1B	FTXZ35NV1B	FTXZ50NV1B
OUTDOOR UNIT		RXZ25NV1B	RXZ35NV1B	RXZ50NV1B
Rated Capacity	Cool (kW)	2.5	3.5	5.0
	Heat (kW)	3.6	5.0	6.3
Capacity Range	Cool (kW)	0.6-3.9	0.6-5.3	0.6-5.8
	Heat (kW)	0.6-7.5	0.6-9.0	0.6-9.4
Indoor Airflow Rate (H)	Cool (l/s)	177	203	250
	Heat (l/s)	195	221	240
Indoor Fan Speeds		5 steps, quiet and automatic		
Energy Label/Star Ratings	Cool	7	5.5	3.5
	Heat	7	5.5	4.5
Front Panel Colour		White		
Power Supply		1 phase, 220-240V, 50Hz		
Power Input (Rated)	Cool (kW)	0.42	0.68	1.18
	Heat (kW)	0.62	0.99	1.37
E.E.R/C.O.P	Cool/Heat	5.95/5.81	5.15/5.05	4.24/4.60
A.E.E.R/A.C.O.P	Cool/Heat	5.90/5.77	5.12/5.03	4.23/4.59
Dimensions (HxWxD)	Indoor (mm)	295x798x372		
	Outdoor (mm)	693x795x300		
Weight	Indoor (kg)	15	15	15
	Outdoor (kg)	50	50	50
Compressor Type		Hermetically sealed swing type		
Refrigerant Type		R32		
Max Pipe Length	(m)	10	10	10
Max Level Difference	(m)	8	8	8
Pipe Sizes	Liquid (mm)	6.4	6.4	6.4
	Gas (mm)	9.5	9.5	9.5
Outdoor Operating Range	Cool (°CDB)	-10 to 43		
	Heat (°CWB)	-20 to 18		
Indoor Sound Level (H/SL)	Cool (dBA)	38/19	42/19	47/23
	Heat (dBA)	39/19	42/19	44/24
Outdoor Sound Level (H/SL)	Cool (dBA)	46	48	49
	Heat (dBA)	46	48	50
Outdoor EPA Sound Power Level (H)	Cool (dBA)	59	61	63
	Heat (dBA)	59	61	64

PRODUCT SPECIFICATION

Zena - Reverse Cycle



WHITE FINISH

SILVER FINISH



INDOOR UNIT		FTXJ25PVMAW	FTXJ35PVMAW	FTXJ50PVMAW	FTXJ25PVMAS	FTXJ35PVMAS	FTXJ50PVMAS
OUTDOOR UNIT		RXJ25PVMA	RXJ35PVMA	RXJ50PVMA	RXJ25PVMA	RXJ35PVMA	RXJ50PVMA
Rated Capacity	Cool (kW)	2.5	3.5	5.0	2.5	3.5	5.0
	Heat (kW)	3.2	4.0	5.8	3.2	4.0	5.8
Capacity Range	Cool (kW)	0.9-3.3	0.9-4.1	1.4-5.5	0.9-3.3	0.9-4.1	1.4-5.5
	Heat (kW)	0.9-4.7	0.9-5.1	1.1-7.0	0.9-4.7	0.9-5.1	1.1-7.0
Indoor Airflow Rate (H)	Cool (l/s)	138	177	180	138	177	180
	Heat (l/s)	173	198	207	173	198	207
Indoor Fan Speeds		5 steps, quiet and automatic					
Energy Label/Star Ratings	Cool	4.5	3	2	4.5	3	2
	Heat	4.5	3.5	2.5	4.5	3.5	2.5
Front Panel Colour		White			Silver		
Power Supply		1 phase, 220-240V, 50Hz					
Power Input (Rated)	Cool (kW)	0.54	0.92	1.47	0.54	0.92	1.47
	Heat (kW)	0.7	0.99	1.59	0.7	0.99	1.59
E.E.R/C.O.P	Cool/Heat	4.63/4.57	3.80/4.04	3.40/3.65	4.63/4.57	3.80/4.04	3.40/3.65
A.E.E.R/A.C.O.P	Cool/Heat	4.56/4.52	3.77/4.01	3.38/3.63	4.56/4.52	3.77/4.01	3.38/3.63
Dimensions (HxWxD)	Indoor (mm)	303x998x212			303x998x212		
	Outdoor (mm)	550x765x285		735x825x300	550x765x285		735x825x300
Weight	Indoor (kg)	12	12	12	12	12	12
	Outdoor (kg)	34	34	47	34	34	47
Compressor Type		Hermetically Sealed Swing Type					
Refrigerant Type		R32					
Max Pipe Length	(m)	20	20	30	20	20	30
Max Level Difference	(m)	15	15	20	15	15	20
Pipe Sizes	Liquid (mm)	6.4	6.4	6.4	6.4	6.4	6.4
	Gas (mm)	9.5	9.5	12.7	9.5	9.5	12.7
Outdoor Operating Range	Cool (°CDB)	-10 to 46					
	Heat (°CWB)	-15 to 18					
Indoor Sound Level (H/SL)	Cool (dBA)	38/19	45/20	46/32	38/19	45/20	46/32
	Heat (dBA)	41/19	45/20	47/32	41/19	45/20	47/32
Outdoor Sound Level (H/SL)	Cool (dBA)	46/43	48/45	48/45	46/43	48/45	48/45
	Heat (dBA)	47/44	48/45	48/45	47/44	48/45	48/45
Outdoor EPA Sound Power Level (H)	Cool (dBA)	58	60	60	58	60	60
	Heat (dBA)	59	60	60	59	60	60

PRODUCT SPECIFICATION

Cora - Reverse Cycle



INDOOR UNIT		FTXM20QVMA	FTXM25QVMA	FTXM35QVMA	FTXM46QVMA	FTXM50QVMA	FTXM60QVMA	FTXM71QVMA	FTXM85PVMA	FTXM95PVMA
OUTDOOR UNIT		RXM20QVMA	RXM25QVMA	RXM35QVMA	RXM46QVMA	RXM50QVMA	RXM60QVMA	RXM71QVMA	RXM85PVMA	RXM95PVMA
Rated Capacity	Cool (kW)	2.0	2.5	3.5	4.6	5.0	6.0	7.1	8.5	9.4
	Heat (kW)	2.7	3.2	3.7	4.7	6.0	7.2	8.0	9.0	10.3
Capacity Range	Cool (kW)	0.9-2.8	0.9-3.7	0.9-4.2	0.9-5.5	1.1-6.7	1.1-7.5	2.0-8.9	2.0-10.5	2.0-11.2
	Heat (kW)	0.9-4.3	0.9-5.3	0.9-5.3	1.0-6.7	1.0-8.0	1.0-8.6	2.0-10.6	1.9-11.6	1.9-12.0
Indoor Airflow Rate (H)	Cool (l/s)	152	167	175	203	267	310	310	358	372
	Heat (l/s)	157	168	183	202	287	333	328	422	413
Indoor Fan Speeds		5 steps, quiet and automatic								
Energy Label/Star Ratings	Cool	5	5	3.5	3	4	3	2.5	2	2
	Heat	5	5	5	3.5	4	3.5	3	2.5	2
Front Panel Colour		White								
Power Supply		1 phase, 220-240V, 50Hz								
Power Input (Rated)	Cool (kW)	0.40	0.49	0.81	1.20	1.14	1.52	1.93	2.49	2.79
	Heat (kW)	0.55	0.65	0.77	1.13	1.33	1.74	2.02	2.42	3.07
E.E.R./C.O.P	Cool/Heat	5.00/4.91	5.10/4.92	4.32/4.81	3.83/4.16	4.39/4.51	3.95/4.14	3.68/3.96	3.41/3.72	3.37/3.36
A.E.E.R./A.C.O.P	Cool/Heat	4.82/4.78	4.95/4.92	4.20/4.59	3.79/4.03	4.33/4.43	3.91/4.10	3.53/3.81	3.31/3.62	3.27/3.28
Dimensions (HxWxD)	Indoor (mm)	285x770x223			295x990x263			340x1200x259		
	Outdoor (mm)	550x675x284			695x930x350			990x940x320		
Weight	Indoor (kg)	9	9	9	9	13	13	13	17	18
	Outdoor (kg)	28	30	30	51	54	54	60	80	82
Compressor Type		Hermetically Sealed Swing Type								
Refrigerant Type		R32								
Max Pipe Length	(m)	20	20	20	30	30	30	30	30	30
Max Level Difference	(m)	15	15	15	20	20	20	20	20	20
Pipe Sizes	Liquid (mm)	6.4	6.4	6.4	6.4	6.4	6.4	6.4	6.4	6.4
	Gas (mm)	9.5	9.5	9.5	12.7	12.7	12.7	15.9	15.9	15.9
Outdoor Operating Range	Cool (°CDB)	-10 to 46								
	Heat (°CWB)	-15 to 18								
Indoor Sound Level (H/SL)	Cool (dBA)	38/19	40/19	42/19	44/26	45/28	48/29	49/30	51/37	53/38
	Heat (dBA)	39/20	40/20	42/20	43/26	45/28	48/29	49/30	51/35	52/35
Outdoor Sound Level (H/SL)	Cool (dBA)	46/43	47/43	49/44	47/44	47/44	49/45	53/49	54/51	54/51
	Heat (dBA)	47/44	48/44	49/45	48/45	48/45	52/45	54/49	56/51	55/51
Outdoor EPA Sound Power Level (H)	Cool (dBA)	58	59	61	59	59	61	65	66	66
	Heat (dBA)	59	60	61	60	60	64	66	68	67

PRODUCT SPECIFICATION

Cora - Cooling Only



INDOOR UNIT		FTKM20QVMA	FTKM25QVMA	FTKM35QVMA	FTKM46QVMA	FTKM50QVMA	FTKM60QVMA	FTKM71QVMA	
OUTDOOR UNIT		RKM20QVMA	RKM25QVMA	RKM35QVMA	RKM46QVMA	RKM50QVMA	RKM60QVMA	RKM71QVMA	
Rated Capacity	Cool (kW)	2.0	2.5	3.5	4.6	5.0	6.0	7.1	
Capacity Range	Cool (kW)	0.9-2.8	0.9-3.7	0.9-4.2	0.9-5.5	1.1-6.7	1.1-7.5	2.0-8.9	
Indoor Airflow Rate (H)	Cool (l/s)	152	167	175	203	267	310	310	
Indoor Fan Speeds		5 steps, quiet and automatic							
Energy Label/Star Ratings	Cool	5	5	3.5	3	4	3	2.5	
Front Panel Colour		White							
Power Supply		1 phase, 220-240V, 50Hz							
Power Input (Rated)	Cool (kW)	0.40	0.49	0.81	1.20	1.14	1.52	1.93	
E.E.R	Cool	5.00	5.10	4.32	3.83	4.39	3.95	3.68	
A.E.E.R	Cool	4.82	4.95	4.20	3.79	4.33	3.91	3.53	
Dimensions (HxWxD)	Indoor (mm)	285x770x223				295x990x263			
	Outdoor (mm)	550x675x284				695x930x350			
Weight	Indoor (kg)	9	9	9	9	13	13	13	
	Outdoor (kg)	28	30	30	51	54	54	60	
Compressor Type		Hermetically Sealed Swing Type							
Refrigerant Type		R32							
Max Pipe Length	(m)	20	20	20	30	30	30	30	
Max Level Difference	(m)	15	15	15	20	20	20	20	
Pipe Sizes	Liquid (mm)	6.4	6.4	6.4	6.4	6.4	6.4	6.4	
	Gas (mm)	9.5	9.5	9.5	12.7	12.7	12.7	15.9	
Outdoor Operating Range	Cool (°CDB)	-10 to 46							
Indoor Sound Level (H/SL)	Cool (dBA)	38/19	40/19	42/19	44/26	45/28	48/29	49/30	
Outdoor Sound Level (H/SL)	Cool (dBA)	46/43	47/43	49/44	47/44	47/44	49/45	53/49	
Outdoor EPA Sound Power Level (H)	Cool (dBA)	58	59	61	59	59	61	65	

PRODUCT SPECIFICATION

Nexura - Reverse Cycle



INDOOR UNIT		FVXG25K2V1B	FVXG35K2V1B	FVXG50K2V1B
OUTDOOR UNIT		RXG25L2V1B	RXG35L2V1B	RXG50L2V1B
Rated Capacity	Cool (kW)	2.5	3.5	4.8
	Heat (kW)	3.4	4.5	5.8
Capacity Range	Cool (kW)	1.3-3.0	1.4-3.8	1.7-5.6
	Heat (kW)	1.3-4.5	1.4-5.0	1.7-8.1
Indoor Airflow Rate (H)	Cool (l/s)	148	151	176
	Heat (l/s)	165	170	203
Indoor Fan Speeds		5 steps, quiet and automatic		
Energy Label/Star Ratings	Cool	5	2.5	1.5
	Heat	4	2.5	2.5
Front Panel Colour		White		
Power Supply		1 phase, 220-240V, 50Hz		
Power Input (Rated)	Cool (kW)	0.54	0.94	1.43
	Heat (kW)	0.76	1.21	1.57
E.E.R/C.O.P	Cool/Heat	4.63/4.47	3.72/3.72	3.36/3.69
A.E.E.R/A.C.O.P	Cool/Heat	4.57/4.43	3.69/3.70	3.22/3.57
Dimensions (HxWxD)	Indoor (mm)	600x950x215		
	Outdoor (mm)	550x765x285		735x825x300
Weight	Indoor (kg)	22	22	22
	Outdoor (kg)	35	35	48
Compressor Type		Hermetically sealed swing type		
Refrigerant Type		R410A		
Max Pipe Length	(m)	20	20	30
Max Level Difference	(m)	15	15	20
Pipe Sizes	Liquid (mm)	6.4	6.4	6.4
	Gas (mm)	9.5	9.5	12.7
Outdoor Operating Range	Cool (°CDB)	10 to 46		
	Heat (°CWB)	-15 to 18		
Indoor Sound Level (H/SL)	Cool (dBA)	38/23	39/24	44/32
	Heat (dBA)	39/22	40/23	46/30
Outdoor Sound Level (H/SL)	Cool (dBA)	46/43	48/44	48/44
	Heat (dBA)	47/44	48/45	48/45
Outdoor EPA Sound Power Level (H)	Cool (dBA)	63	63	63
	Heat (dBA)	63	63	63

PRODUCT SPECIFICATION

Floor Standing - Reverse Cycle



INDOOR UNIT		FVXS25RV1A	FVXS35RV1A	FVXS45LV1A	FVXS50RV1A	FVXS60LVMA	FVXS71LVMA
OUTDOOR UNIT		RXS25RV1A	RXS35RV1A	RXS45LAVMA	RXS50RV1A	RXS60LAVMA	RXS71LAVMA
Rated Capacity	Cool (kW)	2.46	3.5	4.5	5.0	6.0	7.1
	Heat (kW)	2.9	4.52	5.68	5.8	7.0	7.65
Capacity Range	Cool (kW)	1.3-3.0	1.7-3.8	1.7-5.0	1.7-5.6	2.3-6.7	3.0-8.5
	Heat (kW)	1.3-4.5	1.7-5.0	1.7-8.1	1.7-8.1	2.3-9.0	3.0-10.0
Indoor Airflow Rate (H)	Cool (l/s)	137	147	178	260	292	273
	Heat (l/s)	170	170	196	327	285	317
Indoor Fan Speeds		5 steps, quiet and automatic					
Energy Label/Star Ratings	Cool	3.5	3	2	3	2.5	2
	Heat	4.5	3	2.5	3.5	2	2
Front Panel Colour		White					
Power Supply		1 phase, 220-240V, 50Hz					
Power Input (Rated)	Cool (kW)	0.59	0.91	1.37	1.29	1.7	2.13
	Heat (kW)	0.63	1.16	1.61	1.44	2.03	2.21
E.E.R/C.O.P	Cool/Heat	4.17/4.60	3.85/3.90	3.28/3.53	3.88/4.03	3.53/3.45	3.33 / 3.46
A.E.E.R/A.C.O.P	Cool/Heat	4.12/4.55	3.82/3.87	3.27/3.51	3.86/4.01	3.51/3.44	3.32/3.45
Dimensions (HxWxD)	Indoor (mm)	600x700x210			770x850x290		
	Outdoor (mm)	550x765x285	735x825x300		770x900x320	990 x 940 x 320	
Weight	Indoor (kg)	14	14	14	25	25	25
	Outdoor (kg)	34	46	46	46	71	80
Compressor Type		Hermetically sealed swing type					
Refrigerant Type		R410A					
Max Pipe Length	(m)	20	30	30	30	30	30
Max Level Difference	(m)	15	20	20	20	20	20
Pipe Sizes	Liquid (mm)	6.4	6.4	6.4	6.4	6.4	9.5
	Gas (mm)	9.5	12.7	12.7	12.7	12.7	15.9
Outdoor Operating Range	Cool (°CDB)	10 to 46					
	Heat (°CWB)	-15 to 18					
Indoor Sound Level (H/SL)	Cool (dBA)	38/23	39/24	44/32	45/32	47/33	46/33
	Heat (dBA)	41/23	41/24	45/32	49/32	45/33	47/34
Outdoor Sound Level (H/SL)	Cool (dBA)	46/43	47/44	47/44	47/44	49/46	52/49
	Heat (dBA)	50/44	50/45	48/45	51/45	49/46	54/50
Outdoor EPA Sound Power Level (H)	Cool (dBA)	58	59	61	59	63	66
	Heat (dBA)	62	62	62	63	63	66

FEATURES CHECKLIST

	WALL MOUNTED UNIT				FLOOR STANDING UNIT	
	US7	ZENA	CORA		NEXURA	FLOOR STANDING
			Q-SERIES	P-SERIES		
Reverse Cycle (Heating & Cooling)	FTXZ25NV1B FTXZ35NV1B FTXZ50NV1B	FTXJ25PVMAW FTXJ35PVMAW FTXJ50PVMAW FTXJ25PVMAS FTXJ35PVMAS FTXJ50PVMAS	FTX(K)M20QVMA FTX(K)M25QVMA FTX(K)M35QVMA FTX(K)M46QVMA FTX(K)M50QVMA FTX(K)M60QVMA FTX(K)M71QVMA	FTXM85PVMA FTXM95PVMA	FVXG25K2V1B FVXG35K2V1B FVXG50K2V1B	FVXS25RV1A FVXS35RV1A FVXS45LV1A FVXS50RV1A FVXS60LVMA FVXS71LVMA
DC Inverter	✓	✓	✓	✓	✓	✓
PAM Control	✓	✓	✓	✓	✓	✓
Standby Power Function	✓	✓	✓	✓	✓	✓
Power-Airflow Flaps			✓ ¹			
Power-Airflow Dual Flaps	✓	✓	✓ ²	✓		
Wider Angle Louvres	✓	✓	✓	✓	✓	✓
Vertical Auto-Swing (up and down)	✓	✓	✓	✓	✓	✓
Horizontal Auto-Swing (right and left)	✓	✓	✓	✓		
3-D Airflow	✓	✓	✓	✓		
Circulation Airflow	✓					
Breeze Airflow	✓					
Comfortable Airflow	✓	✓	✓	✓		
Indoor Unit Quiet Operation	✓	✓	✓	✓	✓	✓
Outdoor Unit Quiet Operation	✓	✓	✓	✓	✓	✓
Intelligent Eye			✓ ²	✓		
2-Area Intelligent Eye	✓	✓				
New 2-Area Intelligent Eye			✓ ¹			
Automatic Operation	✓	✓	✓ ³	✓	✓	✓
Program Dry Function		✓	✓	✓	✓	✓
Auto Fan Speed	✓	✓	✓	✓	✓	✓
Hot Start	✓	✓	✓ ³	✓	✓	✓
Titanium Apatite Deodorising Filter		✓	✓	✓	✓	✓
Air-Purifying Filter	✓	✓	✓	✓	✓	✓
Wipe Clean	✓	✓	✓	✓	✓	✓
Econo Mode	✓	✓	✓	✓	✓	✓
Radiant Mode					✓	
Powerful Operation	✓	✓	✓	✓	✓	✓
LCD Wireless Remote Control	✓	✓	✓	✓	✓	✓
Indoor Unit On/Off Switch	✓	✓	✓	✓	✓	✓
24-Hour On/Off Timer	✓	✓	✓	✓	✓	✓
Countdown Off Timer	✓					
Quick Heating Timer	✓					
Weekly Timer		✓	✓	✓	✓	✓
Night Set Mode	✓	✓	✓	✓	✓	✓
Auto-Restart after Power Failure	✓	✓	✓	✓	✓	✓
Self Diagnosis with Digital Display	✓	✓	✓	✓	✓	✓
Anticorrosion Treatment of Outdoor Heat Exchanger Fin	✓	✓	✓	✓	✓	✓
Demand Enabled Response (DRED)		✓	✓ ⁴	✓		
Wireless LAN Connection	✓ ⁴	✓ ⁴	✓ ⁵	✓ ⁴		
Multi Colour Monitor Lamp		✓				
0.5°C Step Room Temperature Control			✓			

- 1 Only available for 2.0-4.6 kW Class
- 2 Only available for 5.0-7.1 kW Class
- 3 Only available in Reverse Cycle Models
- 4 Optional Accessory
- 5 Optional Accessory, Remote Control PCB also required (KRP067A41 for 20-46 Class, KRP980B2 for 50-71 Class)

Notes:

- i. The Rated Capacity, Power Input and Running Current are determined under conditions T1 (cooling) or H1 (heating) of AS/NZS 3823.1.1.
Cooling: Indoor temp: 27°CDB/19°CWB
Outdoor temp: 35°CDB/24°CWB
Heating: Indoor temp: 20°CDB/15°CWB
Outdoor temp: 7°CDB/6°CWB
- ii. The cooling (or heating) output capacity will be reduced below the rated value as the outdoor temperature approaches the maximum (or minimum) outdoor temperature operating range limit.
- iii. Indoor and outdoor unit sound levels are determined in an anechoic chamber at a distance of 1 metre from the front of the unit. They are normally higher during actual operation due to ambient conditions.
- iv. Inverter air conditioners do not have a current surge during start up. The compressor start current of an inverter air conditioner is typically lower than specified running current.
- v. The specifications, designs and information in this brochure are subject to change without notice. Unit colours shown are as close as possible to actual unit colours. Colours depicted in this brochure may vary slightly.



The specifications, designs and information in this brochure are subject to change without notice. Unit colours shown are as close as possible to actual unit colours. Colours depicted in this brochure may vary slightly.

ASSUMPTIONS

All representations made in Daikin marketing and promotional material are based on the assumptions that the correct equipment has been selected, appropriately sized and installed in accordance with Daikin's installation instructions and standard industry practices.

QUALITY CERTIFICATIONS

Daikin Industries Limited was the first air conditioning equipment manufacturer in Japan to receive ISO 9001 certification. All Daikin manufacturing facilities have been certified to ISO 9001 Quality Management System requirements. ISO 9001 is a certificate for quality assurance concerning 'design, development, manufacturing, installation and related service' of products manufactured at that factory.

ENVIRONMENTAL CERTIFICATIONS

Daikin Industries Limited has received ISO 14001 Environmental Certification for the Daikin production facilities listed below. ISO 14001 is an international standard specifying requirement for an environmental management system, enabling an organisation to formulate policy and objectives, taking into account legislative requirements and information about significant environmental impacts. It applies to those environmental aspects within the organisation's control and over which it can be expected to have an influence.

The certification relates only to the environmental management system and does not constitute any endorsement of the products shipped from the facility by the International Organisation for Standardisation.

Head Office /Tokyo Office
Shiga Plant (Japan)
Sakai Plant (Japan)
Daikin Industries Ltd (Thailand)
Yodogawa Plant (Japan)
Daikin Australia Pty. Ltd.

Certificate number: EC02J0355
Certificate number: EC99J2044
Certificate number: JOA-E-80009
Certificate number: JOA-E-90108
Certificate number: EC99J2057
Certificate number: CEM20437

**Daikin Australia Pty Limited
(ISO 9001)**
QEC 23256 May 12, 2006
Sydney, Brisbane, Adelaide,
Melbourne, Newcastle,
Townsville, Perth



**Daikin Australia Pty Limited
(ISO 14001)**
CEM 20437 October 27, 2006
Sydney, Brisbane, Adelaide,
Melbourne, Perth



**Residential Air Conditioning
Manufacturing Div (ISO 9001)**
JQA-0486 May 2, 1994
(Shiga Plant)

**Commercial Air Conditioning
and Refrigeration
Manufacturing Div (ISO 9001)**
JMI0107 December 28, 1992
(Kanaoka Factory and Rinkai
Factory at Sakai Plant)

**Industrial System and Chiller
Products Manufacturing Div
(ISO 9001)**
JQA-0495 May 16, 1994
(Yodogawa Plant and Kanaoka
Factory and Kishiwada Factory)

Daikin Europe N.V (ISO 9001)
Lloyd 928589.1 June 2, 1993

Daikin Industries (Thailand) Ltd
JQA-1452 September 13, 2002
(ISO 9001)



DEALER

For all sales enquires email:
sales@daikin.com.au

For customer service or technical support:
1300 368 300

daikin.com.au